

THE PETROLEUM (QUALITY CONTROL) ACT

REGULATIONS
(*under section 19*)

The Petroleum (Quality Control) Regulations, 1990

L.N. 45/90
47/90
61/95
62/95
143/99

THE PETROLEUM (QUALITY CONTROL) ACT

REGULATIONS
(under section 19)

THE PETROLEUM (QUALITY CONTROL) REGULATIONS, 1990

(Made by the Minister on the 2nd day of July, 1990)

L.N. 45/90
Amdt:
L.N. 47/90
61/95
62/95
143/99

1. These Regulations may be cited as the Petroleum (Quality Control) Regulations, 1990.

Interpretation

2. In these Regulations—

“authorized agent” means the Jamaica Bureau of Standards or such other person as may be designated by the Minister.

“blender” means a person engaged in blending;

“blending” means the mixing together of one or more petroleum blending stock with any other substance to form a petroleum product and includes—

(a) the mixing of any substance that may materially affect the composition of any petroleum product as described by the specifications for the product; and

(b) in the case of gasoline, the mixing of oxygenates or other octane enhancers, detergents, antioxidants, corrosion inhibitors and any of the components that are included in the gasoline specifications contained in the Second Schedule;

Second
Schedule.

“bulk distributor” means any person engaged in the distribution of petroleum products by tanker truck, barge or other containers for use by individual retailers or other bulk distributors;

“bulk user” means any person who, other than as a bulk distributor, imports or obtains a petroleum product from a bulk distributor;

“import” means to bring gasoline into Jamaica by cargo tanker or marine vessel;

“importer” means a person who possesses for sale, distribution, transfer or use, any petroleum product or petroleum blending stock imported into Jamaica;

“petroleum blending stock” means any compound which is blended with other compounds to produce a petroleum product;

“petroleum product” means any product specified in the Fourth Schedule;

Fourth
Schedule.

“petroleum refinery” means a facility engaged in producing gasoline, kerosene, distillate fuel oils, residual fuel oils, lubricants, or other products through distillation of petroleum or through redistillation, cracking, extracting or reforming of unfinished petroleum derivatives;

“petroleum shipment” means any petroleum product or petroleum blending stock contained within a single shipment by cargo tanker or marine vessel;

“producer” means a person who manufactures any petroleum product in a petroleum refinery;

“(R+M)/2 Octane rating” means a measure of the ability of gasoline to resist engine knock or pinging as measured by the average of the research octane number and the motor octane number according to procedures in American Standard Test and Measurement methods D-2699 and D-2700;

“service station” means any premises equipped to dispense gasoline into the fuel tanks of motor vehicles or vessels and includes a retail service station, card lock or fleet refueling station.

Licensing of Haulage Contractors

3.—(1) Application for a licence pursuant to section 5 of the Act to operate as a Haulage Contractor shall be in the form prescribed as Form 1 in the First Schedule.

(2) Every such application shall be completed in duplicate and submitted to the Permanent Secretary in the Ministry of Mining and Energy, together with a valid calibration certificate issued to the applicant by the Bureau of Standards in respect of each tank truck or tanker wagon he intends to use for the haulage of petroleum products.

(3) If the application is approved, the licence shall be in the form prescribed as Form 2 in the First Schedule.

Registration of Retailers, Haulage Contractors and Drivers

4.—(1) The Register required to be kept pursuant to section 7 of the Act shall contain the following particulars—

- (a) the name and address of each person registered under the Act;
- (b) in the case of a Retailer, the number and date of issue of the licence issued to him under the relevant Act and the location and grade of the filling station operated by him;
- (c) in the case of a Haulage Contractor—
 - (i) the number and date of issue of the licence granted to him under section 5 of the Act; and
 - (ii) a description of the vehicles, including trailers, operated by him, showing the type, capacity (laden and unladen weight) and registration number of each such vehicle;

- (d) in the case of a Driver, the number and date of expiry of his driver's licence;
- (e) particulars of any character references furnished with an application for registration;
- (f) particulars of any suspension or cancellation of registration pursuant to section 10 of the Act.

(2) Application for registration under the Act shall be in the form prescribed as Form 3 in the First Schedule.

First Schedule.
Form 3.

(3) Every such application shall—

- (a) be completed in duplicate and submitted to the Permanent Secretary in the Ministry of Mining and Energy;
- (b) be accompanied by a recommendation from one of the persons specified on the form;
- (c) where the applicant is a licensed Retailer, be accompanied by a copy of the licence issued to him pursuant to the relevant Act;
- (d) where the applicant is a Haulage Contractor, be accompanied by a copy of the licence issued to him under section 5 of the Act, and a copy of the calibration certificate issued to him by the Bureau of Standards in respect of each tank truck or tanker wagon he intends to use for the haulage of petroleum products.

(4) If the application is approved, the certificate of registration shall be in the form prescribed as Form 4 in the First Schedule.

Form 4.

4A. Where—

- (a) a tank truck or tanker wagon is involved in an accident; or
- (b) any change or modification is made to the carrying compartment of a tank truck or tanker wagon,

that tank truck or tanker wagon shall be re-calibrated by the Bureau of Standards before being put back into service.

Refusal of Applications, Suspension or Cancellation of Registration

5—(1) Where—

- (a) an application for a licence or registration is refused; or
- (b) the registration of any person is cancelled or suspended, notice of such refusal, suspension or cancellation, as the case may be, may be given in the form set out as Form 5 in the First Schedule or in such other form as the Minister may consider appropriate in the circumstances of any particular case.

Form 5.

(2) Any person aggrieved by any direction or order made by the Minister under section 10 of the Act may apply to the Minister in writing to suspend that direction or order pursuant to section 10 aforesaid and shall set out the circumstances which, in the opinion of that person, would merit such suspension by the Minister.

(3) An application pursuant to paragraph (2) shall be made by the person aggrieved not later than fifteen days after receipt by him of notice of the Minister's decision or within such longer period as the Minister may in any case allow.

Certificate of Appointment of Inspector

6. The certificate of appointment of any person designated an inspector under section 16 of the Act shall be in the form set out as Form 6 in the First Schedule.

First
Schedule.
Form 6.

Holding of Enquiry pursuant to section 10

7.—(1) For the purposes of section 10 (1) (b) of the Act, where the Minister considers it expedient so to do, he may appoint a Committee consisting of one person or not more than three persons to determine whether a person registered under the Act (hereinafter referred to as the registered person) procured his registration on the ground of any misleading, false or fraudulent representation.

(2) At least one member of the Committee shall be a person possessing legal qualification and if the Committee consists of more than one person, the person so qualified shall be appointed chairman.

8.—(1) Subject to the provisions of these Regulations the following procedure shall apply to the conduct of an enquiry—

- (a) the Committee shall cause the registered person—
 - (i) to be notified in writing of the allegation made against him and of the intention to conduct the enquiry; and
 - (ii) to be called upon to state in writing before a specified day (not being less than seven days after the date of notification) any relevant facts which he relies on to rebut that allegation;
- (b) if the registered person does not furnish such a statement within the specified time or if, in the opinion of the Committee, he fails to rebut the allegation, the Committee shall inform the registered person that on a day specified the Committee will enquire into the allegation and that he will be permitted to appear before the Committee to defend himself;

- (c) the registered person may be represented at any such enquiry by an attorney-at-law or any other person approved by the Committee;
- (d) if witnesses are examined by the Committee the registered person shall be given an opportunity to be present and to question the witness on his own behalf either personally or through his attorney-at-law or other representative;
- (e) if after hearing the evidence in support of the allegation the Committee is of the opinion that the evidence is insufficient it may report accordingly to the Minister without calling upon the registered person to state his defence;
- (f) in any other case the Committee shall call upon the registered person to state his defence;
- (g) if the Committee is of the opinion that the allegation has been substantiated it shall report accordingly to the Minister and shall recommend to the Minister whether the registration should be—
 - (i) canceled; or
 - (ii) suspended and if so, the period of such suspension.

(2) Where a registered person against whom an allegation is made admits in writing the facts giving rise to the allegation, it shall not be necessary to hold an enquiry under this regulation.

9.—(1) Where the Committee consists of more than one person, the chairman shall have a casting vote in any case in which the voting is equal.

(2) Except as otherwise provided in these Regulations the Committee may regulate its own proceedings.

Presumptions as to Contamination

10.—(1) For the purposes of section 3 (3) (a) of the Act, the normal constituents of each of the categories of petroleum specified in the Second Schedule shall be as set out respectively in that Schedule.

Second
Schedule.

(2) Where as a result of a test of any sample of a category of petroleum a deficiency in the normal constituents of that category is discovered, that deficiency shall raise a presumption that the petroleum from which the sample was taken is contaminated.

(3) The methods for testing the constituents of petroleum products shall be those set out in the Second Schedule.

11. For the purposes of section 3 (3) (b) of the Act, if the actual contents of a prescribed vehicle are found to be different in quality or quantity or in any other respect from the particulars of the petroleum delivered to that vehicle as shown on the despatch note issued in respect of that vehicle and duly stamped by the operator of the refinery or wharf, as the case may be, and initialled by an authorized officer of the refinery or wharf, that discrepancy shall raise a presumption that the petroleum being transport in that vehicle is contaminated.

Transitional

12. Where an application by any person is made pursuant to section 21 of the Act (omitted as transitional *vide* section 11 (1) (a) (viii) of the Law Revision Act) the application shall be accompanied by such documents as would substantiate the applicant's claim to be an "existing operator" as defined in that section.

Licensing of Producers, etc.

Fourth Schedule.
Fifth
Schedule.
Form 1.

13.—(1) A producer, importer, blender, or bulk distributor of any petroleum product specified in the Fourth Schedule, who offers such product for sale or distribution shall apply to the Minister of a licence in Form 1 of the Fifth Schedule;

(2) An application for a licence under this regulation shall be accompanied by an application fee of twenty-five thousand dollars.

Form 2.

(3) A licence issued under this regulation shall be in Form 2 of the Fifth Schedule.

Specifications for Leaded Gasolene

14. Except as provided by regulation 16—

- (a) on and after October 15, 1999, no person shall produce or import into Jamaica any gasolene that contains lead in excess of 0.6 grams per litre;
- (b) on and after January 14, 2000, no person shall sell, offer for sale, distribute, or transport any gasolene that contains lead in excess of 0.6 grams per litre;
- (c) on and after April 1, 2000, no person shall produce or import into Jamaica any gasolene that contains lead in excess of 0.4 grams per litre;
- (d) on and after July 1, 2000, no person shall sell, offer for sale, distribute, or transport any gasolene that contains lead in excess of 0.4 grams per litre;
- (e) on and after April 1, 2003, no person shall produce or import into Jamaica any gasolene that contains lead in excess of 0.013 grams per litre;
- (f) on and after July 1, 2003, no person shall sell, offer for sale, distribute, or transport any gasolene that contains lead in excess of 0.013 grams per litre;

- (g) on and after October 15, 1999, the minimum octane number of gasoline sold, offered for sale, distributed or transported shall be eighty-seven expressed as the $(R+M)/2$, subject to the specifications set out in regulation 4 and the requirements of regulation 6.

Display Fuel Type, etc.

15. On and after January 14, 2000, every retailer or operator of a service station shall display conspicuously on each pump or other device from which gasoline or any other fuel used for motor vehicles is dispensed—

- (a) the type of fuel;
- (b) if the fuel is gasoline, the octane rating expressed as the average of the Research Octane Number and the Motor Octane Number;
- (c) the price per litre of the fuel.

Exemption from Fuel Specifications

16.—(1) In relation to the period between October 15, 1999, and March 31, 2008, regulations 10 and 14 shall not apply in respect of gasoline produced, imported, sold, offered for sale, distributed or transported for use in aviation engines or in competition vehicles that are powered by an engine that—

- (a) requires leaded gasoline with a Research Octane Number of one hundred and nine or greater; and
- (b) has a compression ratio of—
 - (i) 6:1 or greater, in the case of a supercharged or turbo charged engine; or
 - (ii) 12:1 or greater in the case of an engine other than an engine referred to in sub-paragraph (i).

(2) Any person who produces, imports, sells, or offers for sale any gasoline for use in aviation engines or competition vehicles shall keep a record containing—

- (a) the brand name of the gasoline;
- (b) the octane rating of the gasoline and the test method by which the rating was determined;
- (c) the average lead concentration in milligrams of lead per litre of gasoline;
- (e) the name and address of—
 - (i) the distributor or retailer of the gasoline, if the gasoline was used, if the gasoline was sold for distribution or retail; or
 - (ii) the location of a particular track or event where the gasoline was used, if the gasoline was sold at that location; and

- (f) the total quantity of leaded gasoline sold to each of the entities set out in sub-paragraph (d) and the total quantity of any other leaded gasoline produced, imported, sold, offered for sale, distributed or transported.

(3) The records referred to in paragraph (2) shall, in respect of each calendar year, be submitted to the Minister on or before March 31, of the subsequent calendar year.

(4) The records referred to in paragraph (2) shall be retained for a period of three years beginning on the date the record is made.

(5) The Minister may extend any exemption created by this regulation for an additional period, not exceeding five years at a time.

Records

17.—(1) A producer of any of the petroleum products appearing in the Fourth Schedule shall in respect of each year keep a record of the amount of every petroleum product produced.

(2) An importer of petroleum or of any of the petroleum products specified in the First Schedule shall keep a record of the source and disposition of each shipment of petroleum products.

(3) A bulk distributor of petroleum blending stock or of any of the petroleum products specified in the Fourth Schedule shall keep a record of the source of, and every transaction relating to, such blending stock or petroleum product.

(4) A blender of petroleum blending stock or of any of the petroleum products specified in the Fourth Schedule shall keep a record of the volume of each component blended.

(5) Every record referred to in paragraph (1), (2), (3) or (4) shall be retained for a period of three years from the date on which the record is made.

(6) A person who is required by this regulation to maintain a record shall—

- (a) provide a copy of any inspection, including the results of any analyses, carried out under the Act;
- (b) provide a comparison with the specifications, set out in regulation 10, for each quantity of product sold or transferred to a bulk distributor, producer, bulk user or retailer or to any other person to whom the petroleum product is sold or transferred; and
- (c) if requested by the Minister to do so—
 - (i) produce the record for inspection within the time specified in the request;
 - (ii) copy or report in writing to the Minister, the contents of such record as is specified in the request within thirty days of the date of receipt of the written request.

Report to Minister

18.—(1) Every person who produces, imports or exports any petroleum product specified in the Fourth Schedule shall submit to the Minister for each quarter during which the petroleum product is produced, imported or exported, within fifteen days after the last day of each quarter, the information set out in the Sixth Schedule.

Fourth
Schedule.Sixth
Schedule.

(2) Every person who is a producer, importer, bulk distributor or blender of any petroleum product specified in the Fourth Schedule and who sells, distributes or transfers such product to a retailer or to a bulk user shall submit to the Minister, in respect of each quarter during which the petroleum product is sold, and within fifteen days after the last day of each quarter, the information set out in the Sixth Schedule.

Sampling and Analysis of Petroleum Products

19. Every—

- (a) producer, importer, blender or bulk distributor of any petroleum product specified in the Fourth Schedule; or
- (b) retailer or bulk user of gasoline or any petroleum product specified in the Fourth Schedule,

shall provide the Minister or any person authorized by the Minister in writing, with a sample of such gasoline or petroleum product for the purpose of determining the composition or quality of the product compared to the specifications contained in the Second Schedule.

Second
Schedule.*Nature and Disclosure of Gasoline and Diesel Additives*

20.—(1) Any person who is a producer, importer, blender, bulk user or bulk distributor of gasoline or diesel fuel shall—

- (a) use only those additives that are currently approved by the United States Environmental Protection Agency or in the European Union for use in such fuels;
- (b) upon the request of the Minister, or a person authorized by the Minister in writing, provide the Minister or that person with information on—
 - (i) the name of any additive used; and
 - (ii) the purpose of such additives.

(2) The Minister, acting on the advice of the Petroleum Corporation of Jamaica, may, upon the application of any person to whom paragraph (1) applies, approve the use of any additive not specified in paragraph (1) (a) if the applicant demonstrates that the additive—

- (a) is beneficial for operation of the motor vehicle;
- (b) has emission products that are not harmful to the environment or to human health when used in a motor vehicle;
- (c) can be safely used by persons blending the additive; and
- (d) can be safely used in the product containing the additive.

Offences

21.—(1) Any person who offers for sale or distributes any petroleum product that does not meet the specifications contained in the Second Schedule or who contravenes regulation 14 commits an offence and is liable on summary conviction before a Resident Magistrate to—

- (a) a fine not exceeding one hundred and fifty thousand dollars; or
- (b) have any licence issued to him under these Regulations revoked; or
- (c) to both such fine and revocation.

(2) Any person who contravenes regulation 16 (2), (3) or (4), 17, 18 or 19 commits an offence and is liable on summary conviction before a Resident Magistrate to a fine not exceeding one hundred and fifty thousand dollars or to have any licence issued to him under these Regulations revoked or to both such fine and revocation.

(3) Any person who is a retailer or bulk user of any petroleum product used as a fuel and who contravenes regulation 15 or 20 commits an offence and is liable on summary conviction before a Resident Magistrate to a fine not exceeding one hundred and fifty thousand dollars or to have any licence issued to him under these Regulations revoked.

(4) Any person who contravenes regulation 13 commits an offence and is liable on summary conviction before a Resident Magistrate to a fine not exceeding one hundred and fifty thousand dollars.

Role of Minister

22. The Minister, acting on the written advice of the Jamaica Bureau of Standards, may—

- (a) add to the list of petroleum products and fuels set out in the Fourth Schedule;
- (b) revise the specifications and test methods set out in the Second Schedule;
- (c) prescribe gasoline or diesel fuel additives, in addition to those specified in regulation 20 (1), which shall be allowed for use in Jamaica.

Second
Schedule.

Fourth
Schedule.

Second
Schedule.

FIRST SCHEDULE

(Regulations 3, 4 and 6)

FORM 1

(Regulation 2(1))

THE PETROLEUM (QUALITY CONTROL) ACT

THE PETROLEUM (QUALITY CONTROL) REGULATIONS, 1990

Application for Haulage Contractor's Licence

Date of application..... Day Month Year

1. Full name of applicant.....

2. Address.....

(Home)

..... (Business)

3. Telephone No.....

(Private)

(Business)

4. Number of tank wagons or other vehicles, including trailers, to be used for hauling:

(i) gasoline.....

(ii) diesel oil.....

5. Description of vehicles:

(i) Type.....

(ii) Capacity (laden and unladen weight).....

(iii) Registration No.....

(iv) Date of expiration of motor vehicle licence(s).....

(v) Date of expiration of calibration certificate.....

(If space is inadequate, use additional sheet).

6. Number of drivers employed.....

7. If under contract to one or more marketing companies, their names and addresses.....

.....

8. Particulars of any expenses in the business of transporting petroleum in bulk in Jamaica.....

.....

I hereby apply for a licence to operate as a Haulage Contractor under the Petroleum (Quality Control) Act and certify that the particulars set out herein are true and correct.

..... Signature of Applicant

FOR OFFICIAL USE

Licence No.....

Date.....

FIRST SCHEDULE, *contd.*

FORM 2

(Regulation 2(3))

THE PETROLEUM (QUALITY CONTROL) ACT

THE PETROLEUM (QUALITY CONTROL) REGULATIONS, 1990

Licence to Haulage Contractor pursuant to section 5 of the Act

M.....

of.....

is, with effect from.....

(Date)

hereby licensed to operate as a Haulage Contractor to transport petroleum in bulk within the Island on the following conditions—

.....
.....
.....
.....
.....
.....
.....

This Licence is, unless sooner suspended or revoked, valid until.....

(3 years from date of issue)

Minister of Public Utilities
and Transport

FORM 3

(Regulation 5)

THE PETROLEUM (QUALITY CONTROL) ACT

THE PETROLEUM (QUALITY CONTROL) REGULATIONS, 1990

Application for Registration as Retailer, Haulage Contractor or Driver

1. Full Name of Applicant.....

2. Address.....

(Home)

(Business)

3. Telephone No.....

(Private)

(Business)

4. This application should be accompanied by a recommendation from a person specified below.*

(Delete the sectors below not relevant to your application).

SECTOR R

Application for Registration as retailer

A. Location of Filling Station.....

Telephone No.....

FIRST SCHEDULE, *contd.*

FORM 3, *contd.*

F. Particulars of licence granted under section 5 of the Act (attach a copy).....
.....

SECTOR D *Application for Registration as a Driver*

A. General Driver's Licence No.....and
maximum weight (laden and unladen) of vehicles authorized thereby
.....

B. Date of issue of driver's licence.....

C. Particulars of any employment as a tanker driver in the petroleum industry
.....
.....
.....
.....
.....

D. Name and address of employer(s)
in that industry:

From To
— —

.....
.....
.....

*Recommendations may be furnished
by Justices of the Peace, Officers of the
Police Force not below the rank of
Inspector, Resident Magistrates,
members of Parliament or Ministers of
Religion.

.....
Name of Applicant

.....
Date

FOR OFFICIAL USE

Registration No.....
Date registered.....

FIRST SCHEDULE, *contd.*

FORM 4

(Regulation 3 (4))

THE PETROLEUM (QUALITY CONTROL) ACT

THE PETROLEUM (QUALITY CONTROL) REGULATIONS, 1990

Certificate of Registration

This Certifies that

M.....

of.....

is registered in accordance with section 9 of the Petroleum (Quality Control) Act as aand that his/her name has been entered at serial number.....of the Register of Licensed Retailers, Licensed Haulage Contractors and Drivers.

.....
Date

.....
Minister of Mining and Energy

FORM 5

(Regulation 4)

THE PETROLEUM (QUALITY CONTROL) ACT

THE PETROLEUM (QUALITY CONTROL) REGULATIONS, 1990

Notice of—

- (a) refusal of application for licence or registration, or
- (b) suspension or cancellation of registration.

Date.....

To: M.

of.....

Reference: Your—

*application for a *licence/registration dated

* Haulage Contractor's Licence No.

* registration as a

Retailer/Haulage Contractor/Driver

FIRST SCHEDULE, *contd.*

FORM 5, *contd.*

(Complete the appropriate sector below)

SECTOR A
Application The application referred to above for a *licence/registration has been refused on the ground that.....

SECTOR B
Suspension
or
Cancellation The *license/registration referred to above has been *suspended/cancelled with effect from the.....
for a period of.....months
(in the case of suspension)

Pursuant to section 13 of the Act, you have the right to appeal against this decision. The appeal may be made within 15 days of receipt of this notice and shall be addressed to the Secretary of the Tribunal under the Petroleum (Quality Control) Act, c/o The Ministry of Mining and Energy, PCJ Resource Centre, 36 Trafalgar Road, Kingston 10.

*Delete whichever is inapplicable.

.....
Minister of Mining and Energy

FORM 6

(Regulation 5)

THE PETROLEUM (QUALITY CONTROL) ACT

THE PETROLEUM (QUALITY CONTROL) REGULATIONS, 1990

*Certificate of Designation of *Inspector/Analyst*

In accordance with the powers conferred on me by the Petroleum (Quality Control) Act (section 16), I hereby designate

M.....of.....

whose photograph and signature are affixed to this certificate, as an *Inspector/analyst for the purposes of the abovementioned Act.

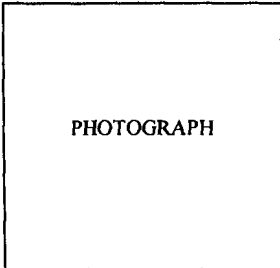

.....
Minister of Mining and Energy

.....
*Signature of * Inspector/Analyst*

.....
Date

*Delete whichever is inapplicable.

SECOND SCHEDULE
Fuel Specifications(Regulations 2,
10 and 21)

Product Type: Gasolene

Property	Minimum	Maximum	Method of test
Density	To be reported		ASTM D4052
Distillation			ASTM D86 as per D4814 Class A
T10, °C		70	
T50, °C	77	121	
T90, °C		190	
Final Boiling Point °C		225	
Recovered Distillation Vol. (%)	98.0		
Sulphur Content %m/m	–	0.15	ASTM D1266, D5453
Lead (g/L) (1,2)		0.013	ASTM D2599, D3237
Copper Corrosion		1	ASTM D130
Existent Gum			
(Solvent Washed) mg/100 ml	–	5	ASTM D381
Oxidation Stability min	240	–	ASTM D525
Reid Vapour Pressure kPa (37.8°C)	–	68.9	ASTM D323, D5191
Total Aromatics (3) % vol.	–	45.0	CAN/CGSB–3.0, 14.3–M94
Benzene Content % vol.	–	5.0	ASTM D3606
Olefins Content (3) % vol.	–	Value to be reported	ASTM D1319
Oxygen (%w/w) (4) or Ethanol (%w/w)		2.7 10.0	ASTM D5895 ASTM D4806
MMT (mg Mn/L)		18	ASTM D–3831
Octane number as (R+M)/2– Regular (5)	87.0		ASTM D2699/2700
All gasolene additives (6)		Brand names to be reported	

NOTES:

1. Applies to unleaded gasolene. All unleaded gasolene must contain sufficient detergent additive to pass the BMW 318i unlimited mileage test (ASTM D5500) using the LAC for additives certified by the US EPA.
2. The content of lead in the leaded regular gasolene shall have the maximum levels as follows.
0.6 g/litre on and after October 15, 1999;
0.4 g/litre on and after April 1, 2000;
0.013 g/litre on and after April 1, 2002.
3. To be reviewed on a yearly basis.
4. For ethers with 5 or more carbon atoms.
5. Or higher than 87 (R+M)/2; value to be indicated as (R+M)/2 to consumers.
6. All gasolene additives must be disclosed and must have current approval by U.S. EPA, European Union or other government jurisdictions approved by the Minister on advice from the Petroleum Corporation of Jamaica.

SECOND SCHEDULE, *contd.*

Product Type: Kerosene

Alternative Description: Domestic Kerosene

Specifications	Minimum	Maximum	Method of test
Appearance	Bright and clear and free from Visible Sediment and water		
Burning Quality	Pass		D-187
Smoke Point mm	20		D-1322
Calorific value (MJ/Kg)	40.4		D-3338
Colour	Blue		
Corrosion Copper—2 hours		3	D-130
Distillation:			D-86
10% Recovery (°C)		205	
FBP °C		300	
Density (15°C) (Kg/m ³)	775	830	D-1298
Flash Point (°C)	38		D-56
Freeze Point (°C)		-30	D-2386
Marker Dye Test	Positive		PJ-02-90-1
Sulphur (%)		0.3	D-2622
Additive:			
Automate Blue (ppm)	14	29	
Oil Marker (ppm)	29	57	
Antioxidant (ppm)	17	24	
Antistatic, Stadis, 450 (ppm)		3	
Conductivity ps/m	80	450	D-2624

SECOND SCHEDULE, *contd.*

Product Type: Aviation Turbo Fuel

Alternative Description: Turbo Fuel Jet A1

Specifications	Minimum	Maximum	Method of test
Acidity, Total (mg KOH/g) (1)		0.015	D-3242
Appearance	Clear, bright and free from Visible Sediment and water at ambient temperature		
Aromatics (vol. %)		22	D-1319
Colour, Saybolt	12		D-156
Copper Content (mg/kg) (2)		0.15	IP-122
Conductivity (ps/m)	50	450	D2624
Corrosion, Cu Strip, 2 hr @ 100°C	1		D-130, IP164
Corrosion, Ag Strip, 4 hr @ 100°C	2		IP227
Distillation (°C)			D-86
IBP	Report		
10% recovered		205	
20% recovered	Report		
50% recovered	Report		
90% recovered	Report		
FBP		300	
Residue (Vol. %)		1.5	
Loss (Vol. %)		1.5	
Flash Point, TCC (°C)	38		D-56
Freeze Point (°C)		-47	D-2386, IP-16
Density @ 15°C (kg/m ³)	39	51	D-1298, IP160
Gum, Existent (mg/100 ml)	7		D-381, IP-131
Heat of combustion net (MJ/Kg)	42.8		D-4529, D-2382
Aniline Gravity Constant.	5,250		D-1298
Water Interaction			D-1094
Separation Rating	2		
Interface Rating		1b	
Separation (8)	Sharp separation, no precipitate within or upon either layer.		
Microseparometer (MSEP) Rating			D-3948
Fuel with Static Dissipator Additive (RDE/A/621)	70		D-2550
Fuel without Static Dissipator	85	6	D-3830
Particulate Matter (mg/l)		1	D-2276
Undissolved Water (ppm)		100	D-3240

(The inclusion of this page is authorized by L.N. 102/2001)

SECOND SCHEDULE, *contd.*Product Type: Aviation Turbo Fuel, *contd.*

Alternative Description: Turbo Fuel Jet A1

Specifications	Minimum	Maximum	Method of test
Marker Dye Test	Negative		PJ-02-90-01
Inhibitors and Additives			
(Antioxidant) mg/l (4)	17	24.0	
Static Dissipator (ppm) ASA 3 (5) Stadis 450		1.0 3.0	
Luminometer No. (6)	45		D-1740
Odour	Satisfactory		
Aromatics, Vol. %		22	D-1319
Sulphur, wt. %			
Mercaptans (7)		0.003	D-3227
Total		0.30	D4294, D-4266
Thermal Stability			
(Jet Fuel Thermal Oxidation Tester)			D-3241
Filter Pressure Drop P (mm Hg)		25	
Tube (deposit) Rating	Less than 3		Visual
Viscosity, cst @ -20°C		8.0	D-445

NOTES: TURBO JET A1 FUEL

- (1) *Acidity*: Sample size shall be 100 ml; normality of potassium hydroxide (KOH) solution shall be 0.01N.
- (2) *Copper Content*: This requirement will be waived for fuels that are not subject to the copper sweetening process
- (3) For estimating net heat of combustion (BTU/LB) from the aniline, Gravity Product, use Table IV; ASTM D-1405, "Heat of Combustion of Aviation Fuels"
- (4) *Antioxidant Inhibitor*: Approved antioxidant or oxidation inhibitor shall be added whenever finished fuel contains 50 per cent or more hydrofined stocks.
- (5) *Static Dissipator*: Additive shall be added at a maximum concentration not to exceed 1.0 ppm to maintain a minimum conductivity of 50 conductivity Units (Cu) and a maximum of 300 Cu at the time and temperature of delivery.
- (6) As alternatives to the minimum Luminometer No. Limit of 45, the following quality requirements are acceptable:
 - Smoke Point of 25 mm minimum, or
 - Smoke Point of 20 mm minimum and 3 vol. % max. naphthalenes
- (7) Alternatively shall pass Doctor Test D-404.
- (8) Small air bubbles or water droplets that may be observed in the fuel layer when examined in a strong beam of transmitted light shall not be cause for rejection.
- (9) Expect 70-95 with the addition of Stadis 450.
- (10) These specifications are at all times at or within the limits of the Aviation Fuel Quality Requirements for Jointly Operated Systems Current Addendum.

SECOND SCHEDULE, *contd.*

Product Type: Distillate Fuel

Alternative Description: Automotive Diesel Oil

Specifications	Minimum	Maximum	Method of test
Ash Content (wt. %)		0.01	D-482
Carbon Residue, Conradson			D-189
wt. on 10% Bottoms		0.10	
Cetane Index (1)	45		D-613
Colour, ASTM		2.0	D-1500
Corrosion, Cu Strip @ 100°C		1	D-130
Distillation, °C			D-86
50% evaporated		288	
90% evaporated		352	
Flashed Point (°C)	60		D-93
Gravity, (2)	.829	.870	D-1298
Neut. No., (TAN), mg/KOH/g			D-974
Odour (3)	Satisfactory		
Pour Point (°C)		-7	D-97
Sediment, suspended, mg/100 ml		0.7	AM-S, 77-060, D-473
Sulphur, wt. %		0.5	D-2622
Viscosity, Kinematic @ 38°C	2.3	4.2	D445
Water by Distillation, Vol. %		0.05	D-95
Marker Dye Test	Negative		PJ-02-90-01

NOTES: (DISTILLATE FUEL)

- (1) Cetane Index (D-976) is calculated from the Gravity and the distillation temperature at which 50% is recovered. Alternatively, a Cetane Number of 45 minimum acceptable.
- (2) Gravity shall be as low as practicable, but abrupt changes should be avoided.
- (3) Suitable level to be established on basis of market requirements.

THIRD SCHEDULE

(Regulation 9)

KEROSENE CONTAMINATION TEST

The test should be conducted by means of a Kit consisting of the following—

1. 2 medicine droppers.
2. 4— $\frac{1}{2}$ oz. bottles each containing a dropper (“dedicated dropper”) and differentiated as follows—
 - (a) Clear premium;
 - (b) Marked premium (premium containing a contaminant);
 - (c) Clear diesel; and
 - (d) Marked diesel (i.e. diesel containing a contaminant).
3. Ultraviolet Lamp.
4. Whatman filter paper.
5. 2B pencil.

- N.B. 1. Read all the instructions carefully before attempting to use this Kit.
 2. “Premium” means premium gasolene and “diesel” means diesel oil.

Procedure

1. Make three “Xs” on a sheet of filter paper and label them A, B and C as shown in Fig. 1 in the Appendix.
2. Using one of the medicine droppers supplies, put a drop of the suspect fuel (Premium or Diesel Oil) on point A.
3. Using the dedicated dropper put one drop of clear premium or clear diesel, as the case may be, on spot B.
4. Using the dedicated dropper put one drop of marked premium or marked diesel, as the case may be, on spot C.
5. Wait five (5) minutes then switch on the lamp.
6. Place the filter paper under the lamp and observe each spot. If the suspect fuel is Diesel Oil the filter paper should also be observed in normal light.
7. Compare the suspect fuel and the clear fuel.
 - (a) The clear fuel is seen as one uniform spot like clear diesel or clear premium.
 - (b) The contaminated fuel is seen as a pink circle in the middle of the spot of the suspect fuel resembling the marked premium or the marked diesel.

- N.B. In the case of diesel, there is evidence of contamination if the pink circle appears either under the lamp or in normal light.

Precaution to be taken when doing the Test

- (a) The dedicated droppers should not be used interchangeably. Each dropper and its bottle is colour coded to prevent confusion as shown in Fig. 2 in the Appendix.
- (b) If there is a mix up of the droppers, they should be washed separately and thoroughly with boiling water.
- (c) If a container is used to make more than one sample it should be washed thoroughly with boiling water after each use.

Detection Limit of the Test

The test will detect a level of contamination of premium or diesel by domestic kerosene where the kerosene content is 0.5 per cent or more.

THIRD SCHEDULE, *contd.*

APPENDIX

Fig. 1

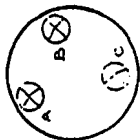
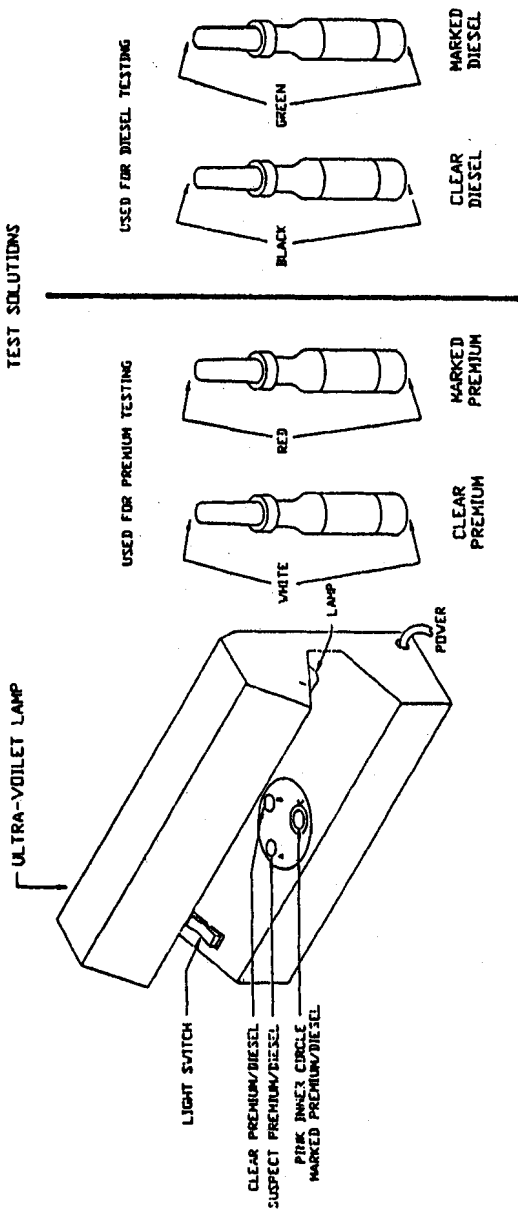

Fig. 2



FOURTH SCHEDULE

(Regulations 2, 13, 17,
18, 19 and 22)*Categories of petroleum products and fuels***Gaseous Fuels**

Butane

Liquefied petroleum gas

Natural gas including compressed natural gas

Propane

Liquid petroleum products

1. Additives for gasoline or automotive diesel

MTBE

Lead

Detergents, antioxidants

Ethanol

Oxygenates

2. All other liquid fuels or petroleum products

Asphalt

Aviation gasoline

Aviation Turbo fuel (Turbo fuel Jet A1)

Crude oil

Crude oil spikes

Distillate fuels (automotive diesel oil)

Gasoline, leaded (all leaded octane grades)

Gasoline, unleaded (all unleaded octane grades)

Kerosene

Lubricants

Naphtha/Solvent

Residual fuel oils

Solid petroleum products

Coal

Any other solid petroleum product

FIFTH SCHEDULE

(Regulations 13)

Form 1

THE PETROLEUM (QUALITY CONTROL) ACT

Application for Importer's, Producer's, Blender's, Bulk Distributor's Licence

(This Form shall be completed in duplicate)

To: The Permanent Secretary
Ministry of Mining and Energy

Date of Application:.....

Full Company Name of Applicant:.....

Business Address:.....

Telephone Number:.....

Fax Number:.....

Type of Applicant (check all that apply):

Producer: Blender

Bulk Distributor Importer

Exempted Fuel

Total daily production, blending or bulk distribution capacity (barrels per day): _____

Total storage capacity (barrels): _____

Location of all blending and storage facilities if different from business address: _____

Description of facilities, including , but not limited to, number and types of blending, storage equipment in use, number of employees, expertise/training of staff, other licences or permits held in connection with the facility, and the reasons or justification for application.

FIFTH SCHEDULE, *contd.*

Form 2

THE PETROLEUM (QUALITY CONTROL) ACT
Blender's, Bulk Distributor's, Importer's or Producer's Licence

(Name of company)

of _____

is, with effect from _____
(Date)

hereby licensed to operate as:

a _____

and a _____

and a _____

and a _____

This licence is, unless sooner suspended or revoked, valid until

(five years from date of issue)

Minister of Mining and Energy

(Regulation 18)

SIXTH SCHEDULE

Quarterly Report Imports and Production	a	b	c	d	e	f	a+b-d-f	Refinery throughput	Thru Bbl/d
Company Period	Opening inventory	Invoice quantity	CIF value (US \$)	Transit gain/losses	Consumed in operation or production	Closing inventory	Net receipts		
	Bbl	Bbl	US \$	Bbl	Bbl	Bbl	Bbl	Bbl	Bbl
Country of origin or destination or local source									
Charcoal									
Natural gas									
Landfill gas									
Biogas									
Liquefied Petroleum gas									
Propane									
Butane									
Oxygenates (MTBE)									
Ethanol for gasoline blending									
Additives (US \$)									
Other blending components									
Production Inputs									
Crude Oil									
Crude Oil spikes									
Whole Naptha									
Kerosene Spike									
Gas Oil Spike									
Butane Spike									
Crude Oil Recon									

SIXTH SCHEDULE, contd.

Quarterly Report Imports and Production Company Period	Country of origin or destination or local source	a Opening inventory Bbl	b Invoice quantity Bbl	c CIF value (US \$) US \$	d Transit gain/losses Bbl	e Consumed in operation or production Bbl	f Closing inventory Bbl	a+b-d-f Net receipts Bbl	Refinery throughput Bbl	Thru Bbl/d
Products Imported Aviation Gasolene Aviation turbo Fuel Automotive Diesel Oil Leaded Gasolene (87) Leaded Gasolene (91) Unleaded Gasolene (87) Unleaded Gasolene (89) Unleaded Gasolene (91) Unleaded Gasolene (other) Kerosene Marine Diesel Oil Residual Fuel Oil (up to 2.2% Sulphur) Residual Fuel Oil (2.2 to 3% Sulphur) Asphalt (60/70) Asphalt (85/100) Naptha/Solvent All other liquid fuels Other fuel oil (waste oil) Lubricants Coal										

SIXTH SCHEDULE, *contd.*

Quarterly Report Imports and Production		a Opening inventory	b Invoice quantity	c CIF value (US \$)	d Transit gain/losses	e Consumed in operation or production	f Closing inventory	a+b-d-f Net receipts	Refinery through- put	Thru Bbl/d
Company Period	Country of origin or destination or local source	Bbl	Bbl	US \$	Bbl	Bbl	Bbl	Bbl	Bbl	
Miscellaneous Fuel Oil Gas Flaring										

[The inclusion of this page is authorized by L.N. 102/2001.]